



moving forward in every field

PERKINS

▶▶ Produktkatalog

www.bepcoparts.com

Member of **TVH** 





PERKINS PARTS

Nouvelle disponibilité en moteurs perkins complets, sans compresseur, démarreur, alternateur et volant moteur
News availabilities of perkins complete engine without compresor, starter, alternator and fly wheel
Neue verfügbare Motor perkins komplette ohne Kompressor, Anlasser, Drehstromlichtmaschine, Schwungrad
Nieuwe beschikbare motor perkins komplet, zonder compressor, startmotor, Wisselstroomdynamo, vliegwiel
Nuevas disponibilidades en motor perkins sin compresor, motor de arranque, alternador y volante de motor



	30/6000-1	30/6000-2	30/6000-3
Model	AD3.152	A4.236	A4.248
Cylinders	3	4	4
Nominal HP	47	70	80

Consultez nous pour tous renseignements complémentaires sur cette nouvelle gamme
Consult us for further information about this new range
Fragen Sie uns für nähere Angaben zu diesem Programm
Raadpleeg ons voor nadere inlichtingen omtrent dit gamma
Consultar nosotros para todas información complementarias con esta nueva gama





TRACPIECES

bepco tractor parts

PRODUCT NEWS-SHEET

PAGE : N° 7045

DATE : 12/99

PERKINS "1000"

Tableau d'identification des tracteurs et des moteurs

Tractors and engines application chart

Vergleichsliste Traktor- und Motortypen

Vergelijingslijst trekkermodellen-motortypen

Tractores y motores, tabla de aplicaciones

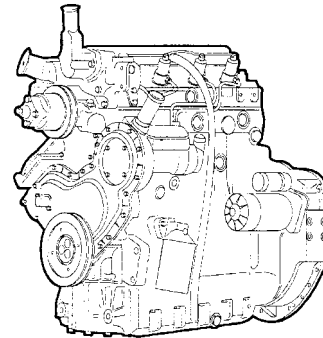

	Modèle Model Modelle Model Modelo	Application Application Anwendung Toepassing Aplicación	Moteur Engine Motor Motor Motor		Modèle Model Modelle Model Modelo	Application Application Anwendung Toepassing Aplicación	Moteur Engine Motor Motor Motor
CATERPILLAR	4161/4281	Backhoe Loader	4.40	CLAAS	D098SL	Combine	T6.60
	4261		T4.40		Dominator 88		
	4361/4381				Dominator 98		
HYSTER	S80-5155XL	Fork Lift Truck	4.40	KOMATSU	PC210	Hydraulic Excavator	T6.60
	H165-280		6.60		PC240		
JCB	712	Dumper	6.60	MASSEY FERGUSON	MF3075, 8937	Agricultural Tractor	1004.4
	809/360 Degree	Excavator	4.40		MF4225, 4235, 4240		4.41 Blue
	820		T6.60		MF4225, 6110, 6120		4.41 Green
	415		T4.40		MF4235, 6130, 6140, 6150		
	410	Loader	4.40		MF4245, 4255, 4265		4.41
	435		T6.60		MF396, 399, 3085, 3095, 3115, 3120		1006.6
	408		Shovel Loader		4.40		MF3125, 3635, 3645, 3655
	412/416				MF4260, 4270		1000-6 Blue
	530/540	Telescopic Handler	T4.40		MF4260, 4270, 8110, 8120		1006-6 Green
	530/540				MF6160, 6170, 6180, 6190		6.60
	716	Truck-Dumper	T6.60		MF8110, 8120, 8130		T6.60
	MANITOU		Telescopic Handler		4.40		

Les références des pièces sont indicatives.
Nos pièces ne sont pas d'origine.



"THE RELIABLE SERVICE"



Part numbers are quoted for reference purposes only.
Our parts and accessories are not original.

PERKINS "1000"

Vilebrequin et pièces connexes
Crankshaft and related parts
Kurbelwelle & Einzelteile
Krukas en bijhorende delen
Cigüeñales y piezas relacionadas

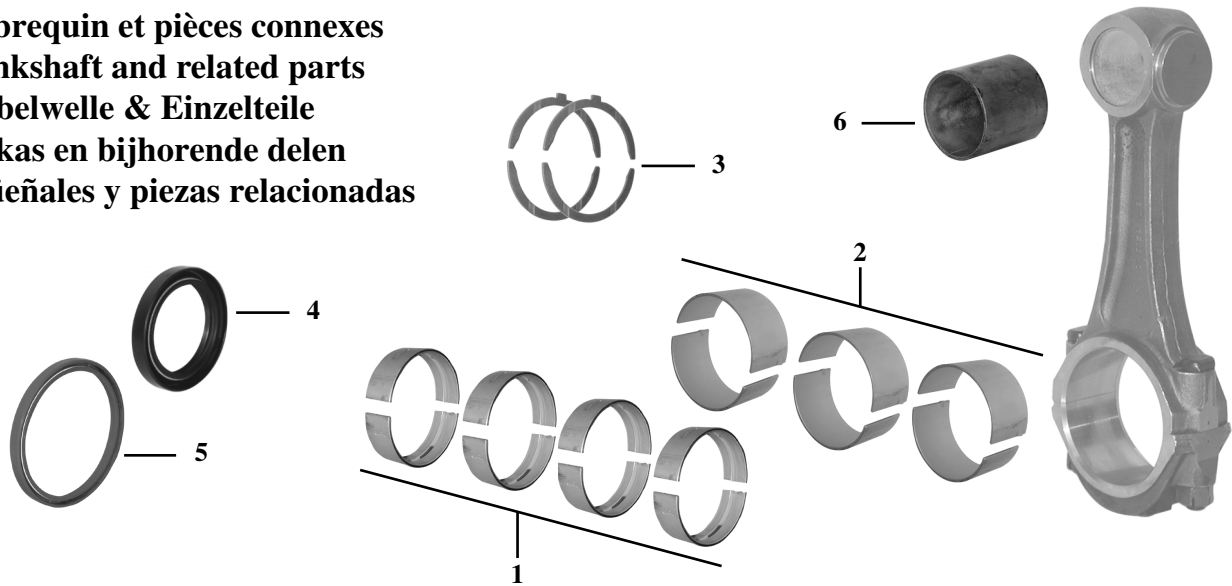

	1	2	3	4	5	6
	Coussinets de palier Main bearing set Hauptlagersatz Hoofdlagerset Cojinete de bancada	Coussinets de bielle Conrod bearing set Pleuellagersatz Drijfstaglagerset Cojinete de biela	Epaisseur latérale Trust washer Anlaufscheiben Axiaallager Arandela	Bague avant Front oil seal Dichtring (Vorn) Keerring voor Retén delantero	Bague arrière Rear oil seal Dichtring (Hinten) Keerring achter Retén trasero	Bague de bielle Small end bush Pleuelbuchsen Pistonpenbus Cojinete pie de biela
MF3075, 8937	30/2-3 (735168M91, 81558)	30/3-28 (3637791M91, U5ME0002)	30/6-3 (2 x 747128M1, + 2 x 747129M1)	30/11-11 (1447690M1, 2418F436)	30/13-4 (1447691M1, 2418F475)	30/28-16 (744971M1, 31134131)
MF4245, 4255, 4265		30/3-3 (736950M91, 85042)				30/28-2 (733767M1, 31134123)
MF4225, 4235, 4240		30/3-28 (3637791M91, U5ME0002)				30/28-16 (744971M1, 31134131)
MF4225, 6110, 6120						
MF4235, 6130, 6140, 6150	30/2-52 (3637020M91, U5MB0007)	30/3-4 (736934M91, 85043)				30/28-2 (733767M1, 31134123)
MF3125, 3635, 3645, 3655		30/3-29 (3637024M91, U5ME0003)				30/28-16 (744971M1, 31134131)
MF4260, 4270, 6160, 6170 (F014037)		30/3-4 (736934M91, 85043)				30/28-2 (733767M1, 31134123)
MF4260, 4270, 6170 (F014038↔), 6180, 6190, 8110, 8120		30/3-29 (3637024M91, U5ME0003)				30/28-16 (744971M1, 31134131)

- Les coussinets de palier et de bielle sont disponibles en côte réparation 0,25mm (0.010"), 0,51mm (0.020"), 0,76mm (0.030") et 1,02mm (0.040"). Ajouter respectivement les suffixes A, B, C ou D.
- Main bearing sets and conrod bearing sets are available in 0,25mm (0.010"), 0,51mm (0.020"), 0,76mm (0.030") and 1,02mm (0.040") undersize. When ordering state standard part number with suffix A, B, C or D respectively.
- Alle Haupt- und Pleuellager sind auch in den Übermassen 0,25mm (0.010"), 0,51mm (0.020"), 0,76mm (0.030") und 1,02mm (0.040") lieferbar. Bitte ergänzen Sie die Bestell-Nr. mit A, B, C oder D.
- De hoofd en drijfstaglagersets zijn beschikbaar in overmaat 0,25mm (0,010"), 0,51mm (0,020"), 0,76mm (0,030") en 1,02mm (0,040"). Voeg dan bij aan het bestelnr.: "A", "B", "C" of "D".
- Los casquillos de bancada y biela están disponibles a 0,25mm (0.010"), 0,51mm (0.020"), 0,76mm (0.030") y 1,02mm (0.040"). Añadir en el pedido el sufijo A, B, C o D respectivamente.

Les références des pièces sont indicatives.
Nos pièces ne sont pas d'origine.

Part numbers are quoted for reference purposes only.
Our parts and accessories are not original.



TRACPIECES

bepco tractor parts

PRODUCT NEWS-SHEET

PAGE : N° 7047

DATE : 12/99

PERKINS "1000"

Joints de moteur
Engine gasket sets
Dichtsätze für Motor
Motordichtungen
Juntas de motor

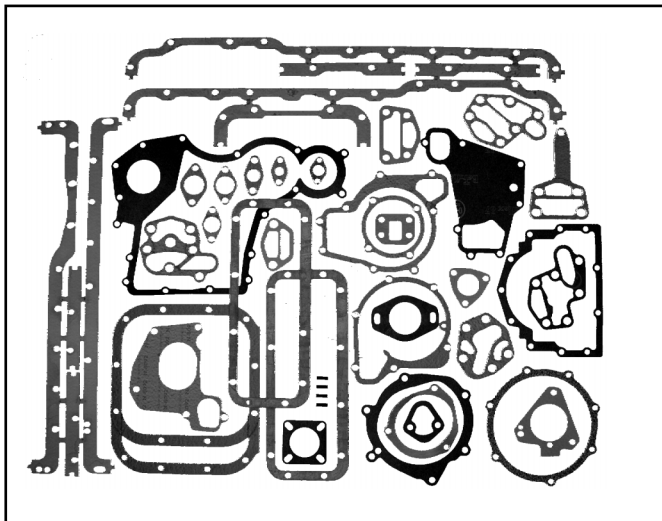

1 —

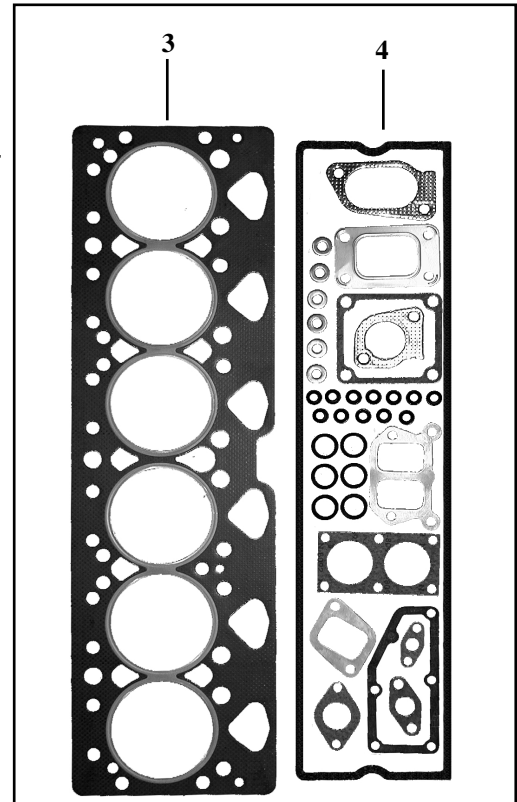

	1	2	3	4
	Pochette rodage Top gaskets Kopfdichtsatz Kopset Kit juntas sup.	Pochette compl. Bottom gaskets Dichtsatz (Unten) Carterset Kit juntas inf.	Joint de culasse Cyl. head gasket Kopfdichtung Koppakking Junta culata	Joint cache soupapes Rocker gasket Ventildeckeldichtung Kleppendecksel-pakking Junta tapa de balancines
Perkins 4.40 & T. 4.40	30/71-90 (3638709M91, U5LT0178)	30/72-90 (3640515M91, U5LB0151)	30/73-90 (3641865M1, 3681E025)	30/74-90 (3640094M1, 3681A021)
Perkins 6.60 & T6.60	30/71-91 (3638697M91, U5LT0179)	30/72-91 (4222229M91, U5LB0153)	30/73-91 (3640916M1, 3681H205)	30/74-91 (748329M1, 3681C001)

Les références des pièces sont indicatives.
 Nos pièces ne sont pas d'origine.



"THE RELIABLE SERVICE"



Part numbers are quoted for reference purposes only.
 Our parts and accessories are not original.

PERKINS "1000"

Soupapes et pièces connexes

Valves & cylinder head parts

Ventile & Einzelteile

Cilinderkop onderdelen

Repuestos para válvulas y culatas

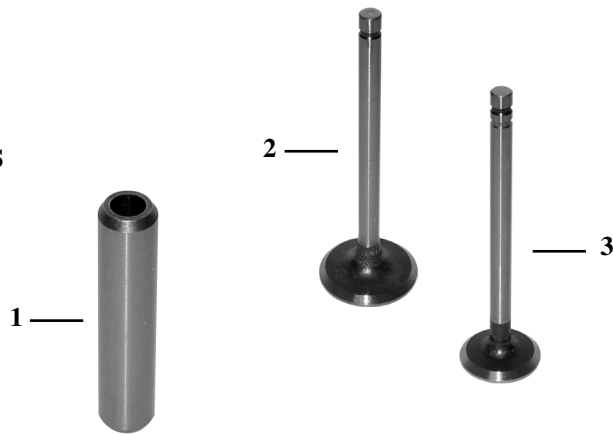

	1	2	3	
	Guide d'admission Inlet guide Einlassventilführung Kleppgeleider Guía admisión	Guide d'échappement Outlet guide Auslassventilführung Kleppgeleider Guía escape	Soupape d'admission Inlet valve Einlassventil Inlaatklep Válvula admisión	Soupape d'échappement Exhaust valve Auslassventil Uitlaatklep Válvula escape
MF3075, 3120, 8937 MF3125 (⇔ U556220X) MF3635, 3645, 3655 MF4245, 4255 MF6130, 6140, 6150 MF6180 (⇔ F017008) MF6190 MF8110 MF8120 (⇔ F044008) MF8130	30/41-17 (3637056M1, 3343F002)	30/41-18 (748420M1, 3343J002)	30/42-39 (3640597M1, 3142L072)	30/43-26 (748309M1, 3142A051)
MF396, 399, 3085, 3115 MF3125 (U556220X ⇔) MF3635, 4260, 4270 MF4225, 4235, 4240 MF6110, 6120, 6160 MF6170 (⇔ F014037)			30/42-38 (748413M1, 3142L051)	

Clavette
Cotter
Ventilkeile
Kleppspieen
Cono válvula

30/46-2

(736453M1, 33173108)



Perkins "1000"

Joint siège Adm./Echap.
Inlet/Outlet seal
Ring Einlassventil/Auslassventil
Inlaatklepzitting/Uitlaatklepzitting
Retén

30/47-1

(3637041M1, 33817125)

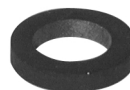

Perkins "1000"

Les références des pièces sont indicatives.
Nos pièces ne sont pas d'origine.

Part numbers are quoted for reference purposes only.
Our parts and accessories are not original.



TRACPIECES

bepco tractor parts

PRODUCT NEWS-SHEET

PAGE : N° 7048

DATE : 12/99

PERKINS "1000"

Pistons, jeux de segments & Chemises / Pistons, ring sets & liners
Kolben, Buchsen und Ringe / Zuigers, zuigerveren & cilinderbussen
Pistones, juegos de anillos, y camisas

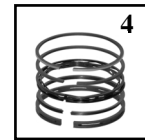
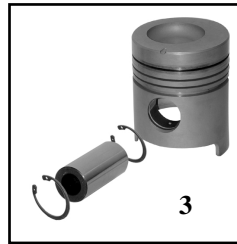
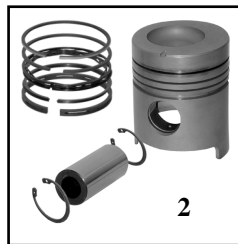

	1	2	3	4	5	
	Jeu Kit set Satz Set Juego	Piston avec segments Piston with rings Kolben mit Ringe Zuiger & zuigerveren Pistón con aros	Piston sans segments Piston less rings Kolben ohne Ringe Zuiger zonder zuigerveren Pistón sin aros	Jeu segments Ring set Satz Kolbenringe Zuigerverenset Juego de segmentos	Chemise finie Finished liner Buchse Afgewerkte cilinderbus Camisa terminada	Chemise semi-finie Semi liner Buchse (halbfertig) Bus half-afgewerkt Camisa semi
MF396, 399, 3085, 3095, 3115	30/31-109	30/32-109	30/33-109 (3638989M91, U5LL0015, 4222706M91)	30/34-110 (3637033M91, 4181A019)	30/35-108 (748216M1, 3135X042)	30/36-108 (748215M1, 3135X041)
MF6160, 6170 (⇔ U593765A)						
MF3075, 8937 MF3120, 3125, 3635, 3645, 3655 MF4245, 4255, 4265 MF6130, 6140, 6150 MF6180, 6190 (⇔ F017008) MF8110, 8120, 8130 (⇔ F044008)	30/31-108	30/32-108	30/33-108 (3638460M91, U5LL0014, 3640593M91)	30/34-108 (3641316M91, 4181A026)		
MF4260, 4270						
MF6160, 6170 (U593766A ⇔)						
MF4235 MF4245, 4255 (Low & High grades)				30/34-108 (3641316M91, 4181A026)		

	30/33-108	30/33-109
Hauteur de compression (mm) Compression height (mm) Kompressionshöhe (mm) Compressiehoogte (mm) Altura compresión (mm)	A	70.02
Profondeur chambre de combustion (mm) Combustion bowl depth (mm) Brennkammerntiefe (mm) Diepte verbrandingskamer (mm) Profundidad cámara de combustión (mm)	B	19.48
Hauteur totale (mm) Overall length (mm) Gesamthöhe (mm) Totale hoogte (mm) Longitud total (mm)	D	108.06

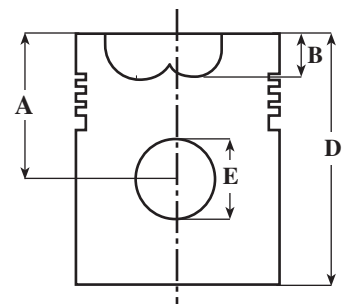
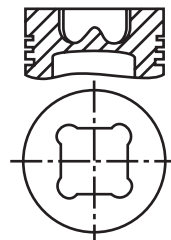

Les références des pièces sont indicatives.
Nos pièces ne sont pas d'origine.

Part numbers are quoted for reference purposes only.
Our parts and accessories are not original.



"THE RELIABLE SERVICE"



PERKINS "1000"



Caractéristiques techniques

Technical data

Technische Daten

Kenmerken

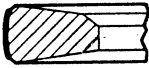
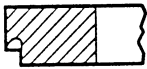
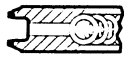
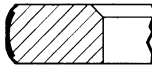
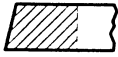
Datos técnicos

30/34-108	Trapézoïdal bilatéral chromé chanfrein intérieur haut Chrome plated keystone internally bevelled top Kolbenring, trapezförmig, verchromt, mit abgesetzter TOP-Kante Trapezium dubbelzijdig verchromd met aafschuining Trapezoidal dos caras con bisel superior (Cromado exterior)		CK3 : 3.500
	Bec d'angle Napier-externally stepped bottom with single hook Abgestufter Kolbenring Uitsparing aan de onderzijde Tipo «Napier» o «Pico de águila»		N1 : 2.500
	Chromé chanfreiné avec ressort hélicoidal Chrome plated bevelled edge with helical coil spring Ölabstreifring, verchromt, mit Spannfeder Met schuine gechromeerde kant en spiraalvormige veer Cromado y rebajado con muelle helicoidal		CBEH : 4.000
30/34-110	Portée bombé molybdène chanfrein intérieur en haut Molybdenum coated barrel faced internally bevelled top Gewölbt molybdänbeschichtet mit oben abgesetzter TOP-Kante Molybdeen gecoatet met afgeschuinde top Recubrimiento exterior de molibdeno, bisel interno superior		MR3 : 2.500
	Portée conique Taper faced plain Kompressionsring (einfach) Conisch dragend Exteriormente cónico		T1 : 2.500
	Chromé chanfreiné avec ressort hélicoidal Chrome plated bevelled edge with helical coil spring Ölabstreifring, verchromt, mit Spannfeder Met schuine gechromeerde kant en spiraalvormige veer Cromado y rebajado con muelle helicoidal		CBEH : 4.000

Alésage (mm) Nominal bore diameter (mm) Bohrung (mm) Boring (mm) Díametro pistón	A	30/35-108	100.00
Diamètre extérieur (mm) Outside diameter (mm) Aussendurchmesser (mm) Buitendiameter (mm) Díametro exterior (mm)	B		104.33
Hauteur totale (mm) Overall length (mm) Gesamthöhe (mm) Totale hoogte (mm) Longitud total (mm)	C		226.44
Diamètre colorette (mm) Flange diameter (mm) Durchmesser Kragen (mm) Diameter v/d kraag (mm) Díametro pestaña (mm.)	D		107.44
Colorette (mm) Flange width (mm) Anschlagflansch Bundhöhe Rand Anchura pestaña	E		3.86

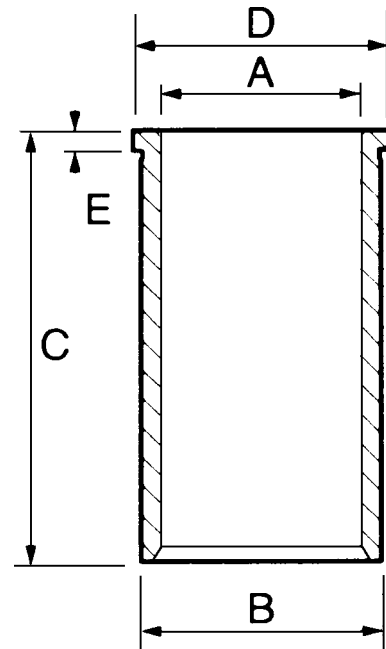

Les références des pièces sont indicatives.
Nos pièces ne sont pas d'origine.

Part numbers are quoted for reference purposes only.
Our parts and accessories are not original.



TRACPIECES

bepco tractor parts

PRODUCT NEWS-SHEET

PAGE : N° 7049

DATE : 12/99

PERKINS "1000"

Pompe d'alimentation et pièces connexes

Fuel pump & parts

Kraftstoffförderpumpe & Einzelteile

Opvoerpomp & onderdelen

Bomba gas-oil y piezas relacionadas

30/100-32

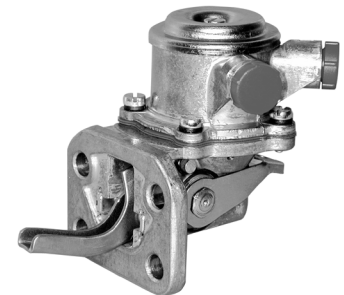

30/100-25

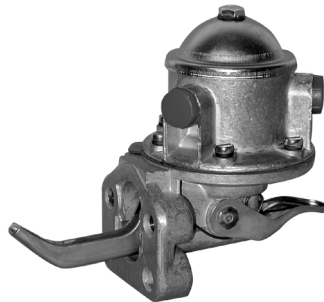

	Pompe d'alimentation Fuel pump Kraftstoffförderpumpe Opvoerpomp Bomba gas-oil	OEM	Jeu de réparation Repair kit Reparatursatz Revisieset Juego de reparación	OEM
MF396 MF399, 699, 3085, 3095, 3115, 3120, MF3125, 3635, 3645, 3655	30/100-25	4222105M91 ULPK0002	30/101-31	3641855M91 26412505 4222219M91
MF3075, 8937	30/100-32	4222106M91 ULPK0005	30/101-10	1896434M91 26410087 4222326M91
MF4225, 4235, 4240				
MF4245, 4255, 4265				
MF4260, 4270	30/100-25	4222105M91 ULPK0002	30/101-31	3641855M91 26412505 4222219M91
MF4270				
MF6110, 6120, 6130, 6140, 6150	30/100-32	4222106M91 ULPK0005	30/101-10	1896434M91 26410087 4222326M91
MF6160, 6170, 6180, 6190	30/100-25	4222105M91 ULPK0002	30/101-31	3641855M91 26412505 4222219M91
MF8110, 8120, 8130				

Les références des pièces sont indicatives.
Nos pièces ne sont pas d'origine.

Part numbers are quoted for reference purposes only.
Our parts and accessories are not original.



"THE RELIABLE SERVICE"



PERKINS "1000"

Pompe à eau et pièces connexes
 Water pump & parts
 Wasserpumpe & Einzelteile
 Waterpomp & onderdelen
 Bomba agua y piezas relacionadas



	Pompe à eau Water pump Wasserpumpe Waterpomp Bomba agua	OEM	Jeu de réparation Repair kit Reparatursatz Revisieset Juego de reparación	
6130, 6140, 6150 8937	30/130-90	U5MW0144 3641869M91 4223566M91	30/131-90 U7LW0071 U7LW0076 3637615M91	Axe / Axe / Welle Pen / Eje Ø 16x30x16
396, 399, 3085, 3095, 3115, 3120, 3125, 3635, 3645, 3655, 4260, 4270, 6160, 6170, 6180, 6190, 8110, 8120, 8130	30/130-91	3641860M91 3638694M91 4222028M91 U5MW0092	30/131-91 U7LW0087 4222052M91	Axe / Axe / Welle Pen / Eje Ø 16x38x19

Thermostat
Thermostat
Thermostat
Thermostaat
Termostato



30/143-18

(1447384M1, 2485613)



3075, 8937, 396, 399, 3085, 3095, 3115, 3120, 3125, 3635,
 3645, 3655, 4225, 4235, 4245, 4255, 4265, 4270,
 4240, 6110, 6120, 6130, 6140, 6150, 6160, 6170, 6180,
 6190, 8110, 8120, 8130

Les références des pièces sont indicatives.
 Nos pièces ne sont pas d'origine.

Part numbers are quoted for reference purposes only.
 Our parts and accessories are not original.



TRACPIECES

bepco tractor parts

PRODUCT NEWS-SHEET

PAGE : N° 7050

DATE : 12/99

PERKINS "1000"

Filtration / Filters / Filter / Filters / Filtros

	Air / Air Luftfilter / Luchtfiter / Aire		Huile Oil Ölfilter Oliefilter Aceite	Combustible Fuel Kraftstoff-Filter Brandstofffilter Combustible	Hydraulique Hydraulic Hydraulik-Filter Hydrauliekfilter Hidráulico
	Ext. / Out. Außen / Buiten Exterior	Int. / Inn. Innen / Binnen Interno			
396	60/161-23 (03595500M1)	60/162-23 (03595501M1)	60/97-3 (267/F) (1447031M1)	60/111-5 (M.1851890) (CAV 7111/296) (836218M91, 3405418M1) 2 x = 60/111-3 (1087/PK) (Repl. CAV 296) 2 x (836218M91, 3405418M1)	60/569-1 (03595175M1) Avec pompe double With tandem pump Mit Tandempumpe Met dubbele pomp Con bomba doble Direction assistée Power steering Lenkungsfilter Stuurbekrachtiging Dirección asistida
399	60/158-9 Filtre complet à bain d'huile Complete oil bath filter Ölbadfilter komplett Komplete Oliebadfilter Filtro completo en baño de aceite ou / or / oder / of / o 60/161-23 (03595500M1) Au-dessus du capot Over bonnet Auf der Motorhaube Boven op motorkap Encima del capó 60/161-24 (03595503M1) En-dessous du capot Under bonnet Unter der Motorhaube Onder de motorkap Debajo del capó	60/159-9 Elément Element Einsatz Inzet Elemento 60/162-23 (03595501M1) 60/162-23 (03595501M1)			60/625-2 (M.1870199) Relevage / Lift Kraftheber Lift / Elevación ou / or / oder / of / o 60/625-4 (025015M91) Avec pompe double With tandem pump Mit Tandempumpe Met dubbele pomp Con bomba doble Relevage / Lift Kraftheber Lift / Elevación
3075	60/161-25 (M.1062501) (1062501M1)	60/162-25 (P.2651/0228) (1093683M92)	60/97-2 (599AR/F) Ht. / Ht. H. / H. / Altura 142 mm (1447048M1)	60/111-63 (7176/496) (CAV 496) (3638291M1) = 60/111-25 (5006/F) (Repl. CAV 496) (3638291M1)	60/625-5 (03581032M2) A visser / Spin on Aufschraub./ Geschroefd Roscado Ht. / Ht. / H. / H. / Altura 165mm (↔ S95020)
3085, 3095, 3115 3120			60/97-3 (267/F) (1447031M1)	60/111-63 (7176/496) (CAV 496) (3638291M1) = 60/111-25 (5006/F) (Repl. CAV 496) (3638291M1)	60/625-6 (03616579M1) A visser / Spin on Aufschraub./ Geschroefd Roscado Ht. / Ht. / H. / H. / Altura 98mm (S95020 ↔)
3125	60/161-27 (03385733M1)	60/162-27 (03385734M1)		60/111-5 (M.1851890) (CAV 7111/296) (836218M91, 3405418M1) 2 x = 60/111-3 (1087/PK) (Repl. CAV 296) 2 x (836218M91, 3405418M1)	60/240-41 (03619594M1) Crépine / Strainer Einsatz/ Aanzuigfilter Filtro de rejilla 60/574-7 (03615949M1) Direction assistée Power steering Lenkungsfilter Stuurbekrachtiging Dirección asistida

Les références des pièces sont indicatives.
Nos pièces ne sont pas d'origine.



"THE RELIABLE SERVICE"



Part numbers are quoted for reference purposes only.
Our parts and accessories are not original.

PERKINS "1000"

Filtration / Filters / Filter / Filters / Filtros

	Air / Air Luftfilter / Luchtfiter / Aire		Huile Oil Ölfilter Oliefilter Aceite	Combustible Fuel Kraftstoff-Filter Brandstofffilter Combustible	Hydraulique Hydraulic Hydraulik-Filter Hydrauliekfilter Hidráulico
	Ext. / Out. Außen / Buiten Exterior	Int. / Inn. Innen / Binnen Interno			
3635, 3645, 3655	60/161-27 (03385733M1)	60/162-27 (03385734M1)	60/97-2 (599AR/F) (1447048M1)	60/111-5 (M.1851890) (CAV 7111/296) (836218M91, 3405418M1) = 60/111-3 (1087/PK) (Repl. CAV 296) (836218M91, 3405418M1) ou / or / oder / of / o 60/111-63 (7176/496) (CAV 496) (3638291M1) = 60/111-25 (5006/F) (Repl. CAV 496) (3638291M1)	60/625-7 (03386701M1) Relevage / Lift Kraftheber Lift / Elevación
4225, 4235	60/161-118 (3901462M1) 305mm 60/161-119 (3901464M1) 345mm	60/162-118 (3901463M1) 319,3mm 60/162-119 (3901465M1) 359,3mm		60/111-63 (7176/496) (CAV 496) (3638291M1) = 60/111-25 (5006/F) (Repl. CAV 496) (3638291M1)	
4245, 4255, 4265	60/161-119 (3901464M1) 345mm 60/161-120 (3901475M1) 360mm	60/162-119 (3901465M1) 359,3mm 60/162-120 (3901476M1) 373,8mm	60/97-3 (599AR/F) (1447031M1)	60/111-5 (M.1851890) (CAV 7111/296) (836218M91, 3405418M1) = 60/111-3 (1087/PK) (Repl. CAV 296) (836218M91, 3405418M1)	
4260, 4270	60/161-120 (3901475M1) 360mm 60/161-121 (3901477M1) 385mm	60/162-120 (3901476M1) 373,8mm 60/162-121 (3901478M1) 398,5mm		60/111-5 (M.1851890) (CAV 7111/296) (836218M91, 3405418M1) = 60/111-3 (1087/PK) (Repl. CAV 296) (836218M91, 3405418M1) 2 x	
6110 6120, 6130, 6140, 6150	60/161-25 (M.1062501) (1062501M1)	60/162-25 (P.2651/0228) (1093683M92)	60/97-2 (599AR/F) (1447048M1)	60/111-63 (7176/496) (CAV 496) (3638291M1) = 60/111-25 (5006/F) (Repl. CAV 496) (3638291M1)	60/625-6 (03616579M1) A visser / Spin on Aufschraub- / Geschroefd Roscado Relevage / Lift Kraftheber Lift / Elevación
6160, 6170, 6180			60/97-3 (267/F) (1447031M1) 2 x	60/111-63 (7176/496) (CAV 496) (3638291M1) 2 x = 60/111-25 (5006/F) (Repl. CAV 496) (3638291M1) 2 x	60/240-40 (03618662M1) Crépine / Strainer Einsatz/ Aanzuigfilter Filtro de rejilla

Les références des pièces sont indicatives.
Nos pièces ne sont pas d'origine.

Part numbers are quoted for reference purposes only.
Our parts and accessories are not original.



TRACPIECES

bepco tractor parts

PRODUCT NEWS-SHEET

PAGE : N° 7053

DATE : 12/99

PERKINS "1000"

Filtration / Filters / Filter / Filters / Filtros

	Air / Air Luftfilter / Luchtfiter / Aire		Huile Oil Ölfilter Olielfiter Aceite	Combustible Fuel Kraftstoff-Filter Brandstofffilter Combustible	Hydraulique Hydraulic Hydraulik-Filter Hydrauliekfilter Hidráulico
	Ext. / Out. Außen / Buiten Exterior	Int. / Inn. Innen / Binnen Interno			
6190	60/161-27 (03385733M1)	60/162-27 (03385734M1)	60/97-3 (267/F) (1447031M1)	60/111-63 (7176/496) (CAV 496) (3638291M1) 2 x = 60/111-25 (5006/F) (Repl. CAV 496) (3638291M1) 2 x	60/625-7 (03386701M1) A visser / Spin on Aufschraub./ Geschroefd Roscado ou / or / oder / of / o 60/240-40 (03618662M1) Crépine / Strainer Einsatz/ Aanzuigfilter Filtro de rejilla
8110, 8120, 8130, 8140, 8150, 8160	60/161-27 (03385733M1)	60/162-27 (03385734M1)	60/97-3 (267/F) (1447031M1) 2 x	60/111-63 (7176/496) (CAV 496) (3638291M1) 2 x = 60/111-25 (5006/F) (Repl. CAV 496) (3638291M1) 2 x	60/625-7 (03386701M1) A visser / Spin on Aufschraub./ Geschroefd Roscado 60/625-9 (03619712M1) A visser / Spin on Aufschraub./ Geschroefd Roscado LOAD SENSING ou / or / oder / of / o 60/240-40 (03618662M1) Crépine / Strainer Einsatz/ Aanzuigfilter Filtro de rejilla
8937					

Les références des pièces sont indicatives.
Nos pièces ne sont pas d'origine.



"THE RELIABLE SERVICE"



Part numbers are quoted for reference purposes only.
Our parts and accessories are not original.



PERKINS PARTS

Nouvelle disponibilité en short bloc (complet)
News availabilities of short bloc (complete)
Neue verfügbare Motorblock (Komplett)
Nieuwe beschikbare motorblok (kompleet)
Nuevas disponibilidades en motor bloqueo (completo)

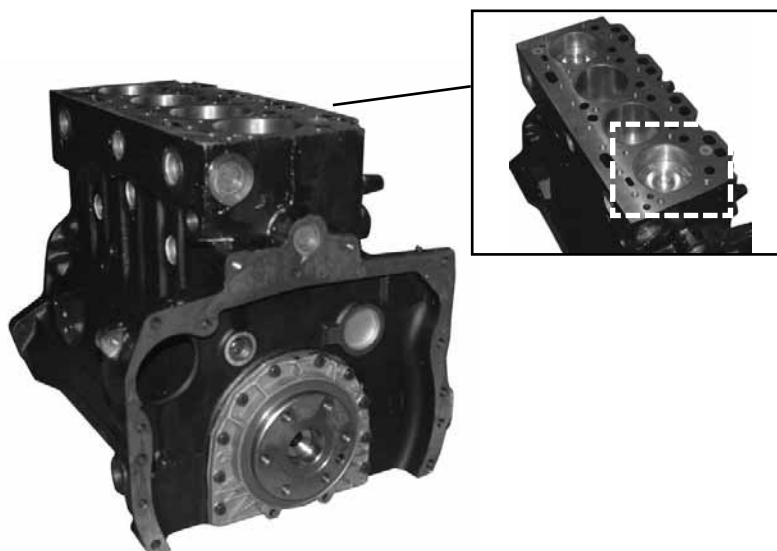

Short block Motorblock Motorblok Motor bloqueo	Piston Kolben Zuiger Pistón	Model	Cylinders	Nominal HP
30/6001-5	-	A4.248	4	80
30/6001-6	-	A4.236		70

Consultez nous pour tous renseignements complémentaires sur cette nouvelle gamme
Consult us for further information about this new range
Fragen Sie uns für nähere Angaben zu diesem Programm
Raadpleeg ons voor nadere inlichtingen omtrent dit gamma
Consultar nosotros para todas información complementarias con esta nueva gama





PERKINS PARTS

Injection - Injection - Einspritzung - Injctie - Inyección



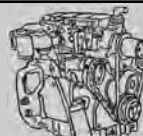

	Fig. Abb. Afb. Fig.	Parts N°	Description Beschreibung Omschrijving Descripción	Rotation Drehrichtung Draairichting Rotación
D3.152	1	30/7100-1854	Pompe injection	↻
4.236 4.248		30/7100-1855	Injection pump	↻
6.354.4		30/7100-1856	Einspritzpumpe Brandstofpomp Bomba inyección	↻
3, 4 & 6 Cyl. Perkins	2	30/117-238	Injecteur complet Complete injector Komplette duse Komplete verstuiver Tobera completo	-





PERKINS PARTS

REFROIDISSEUR D'HUILE - OIL COOLER - ÖLKÜLHER - OLIE KOELER - REFRIGERADOR ACEITE

	N° de construction <i>Build number</i>	Ref.	
A4.236	LD, LJ, LH	30/6097-3 (P2486A219)	
1004.4	AA, AB, AE, AJ, AK, AQ, AR, AS		



**BEPCO PARTS SA****HERMALLE-SOUS-HUY**

Rue Chaumont, 4D • 4480 Hermalle-sous-Huy • Belgique
 T +32 85 24 54 00 • F +32 85 24 54 50
 info.be@bepcoparts.com • www.bepcoparts.com

VILLERS-LE-BOUILLET

Rue de Waremme, 114 • 4530 Villers-le-Bouillet • Belgique
 T +32 85 24 54 00 • F +32 85 24 54 50
 info.be@bepcoparts.com • www.bepcoparts.com

**BEPCO UK LTD**

Bepco House • Unit 316 • Hartlebury Trading Estate
 Hartlebury - Worcestershire, DY10 4JB (UK)
 P +44 (0)1299 252270 • F 0800 216553
 info@bepcoparts.com • www.bepcoparts.com

**BEPCO FRANCE SAS**

Z.I. La Plaine, Allée de Bigorre
 BP80041 Le Passage • 47901 Agen Cedex 9 • France
 T +33 (0)553 96 31 25 • F +33 (0)553 68 03 72
 info.fr@bepcoparts.com • www.bepcoparts.com

VILLENEUVE-SUR-LOT

294 Av. de Bordeaux • CS 30059 Bias
 FR-47302 Villeneuve sur lot • France
 T +33 (0)5 53 40 37 50 • F +33 (0)5 53 70 61 93

JANZÉ

P.A. de la Chauvelière • Rue Charles Lindbergh
 35150 JANZE • France
 T + 33 (0)2 99 44 16 18 • F +33 (0)2 99 44 17 29

**TVH AUSTRALASIA PTY LTD**

HEAD OFFICE BRISBANE • www.bepcoparts.com

ADELAIDE

96 South Terrace • Wingfield SA 5013
 Free 1800 182 344 • T +61 8 8359 8933 • F +61 8 8234 2212
 BepcoSAsales@tvh.com.au

BRISBANE

735 Boundary Road • Richlands QLD 4077
 Free 1800 020 082 • T +61 7 3344 1113 • F +61 7 3344 1332
 BepcoQLDsales@tvh.com.au

MELBOURNE

7/66-74 Micro Circuit • Dandenong South VIC 3175
 Free 1800 802 367 • T +61 3 9796 5422 • F +61 3 9796 5251
 BepcoVICsales@tvh.com.au

PERTH

2/15 Colin Jamieson Drive • Welshpool WA 6106
 Free 1800 182 344 • T +61 8 8352 8984 • F +61 8 8234 2212
 BepcoWAsales@tvh.com.au

SYDNEY

1/1002-1010 Canley Vale Rd • Wetherill Park NSW 2164
 Free 1800 808 827 • T +61 2 6885 5288 • F +61 3 9796 5251
 BepcoNSWsales@tvh.com.au

**TVH NEW ZEALAND LTD****AUCKLAND**

PO Box 51490 • Pakuranga 2140 • 11K Echelon Place
 East Tamaki • Auckland
 Free 0800 459 662 • T +64 9 274 9695 • F +64 9 274 9698
 info@tvh.co.nz • www.tvh.com

CHRISTCHURCH

11C Parkhouse Road
 Wigram • Christchurch 8042
 Free 0508 8 722 867 • T +64 3 550 1298 • F +64 3 974 9993
 infochch@tvh.co.nz

**BEPCO Deutschland GmbH**

Nelmannwall 4 • 59494 Soest • Germany
 T +49 (0)2921 943000 • F +49 (0)2921 7696440
 info.de@bepcoparts.com • www.bepcoparts.com

**BEPCO NEDERLAND BV**

Den Dolvert 10 • 5473 GP, Heeswijk-Dinther • Nederland
 T +31 (0)413 29 39 75 • F +31 (0)413 29 40 87
 info.nl@bepcoparts.com • www.bepcoparts.com

**BEPCO IBÉRICA SA**

Pol. Ind. Les Guixeres, C/ Xarol, 7
 08915 Badalona (Barcelona) • Spain
 T +34 902 111 062 - 933 810 062 • F +34 933 813 345
 info.es@bepcoparts.com • www.bepcoparts.com

ALMENDRALEJO

Ctra. Badajoz - Pol. «Rayvaz» Nave 21
 06200 Almendralejo (Badajoz)
 T +34 (0)902 111 062 - 924 664 890
 F +34 (0)924 664 576

DOS HERMANAS

Pol. Ind. La Isla, C/ Hornos, 11
 41703 Dos Hermanas (Sevilla)
 T +34 (0)902 111 062 - 954 931 546
 F +34 (0)954 930 130

SANTIAGO DE COMPOSTELA

Pol. El Tambre, Via Faraday, 36
 15890 Santiago de Compostela
 T +34 (0)902 111 062 - 981 560 012
 F +34 (0)981 557 753

**TVH PARTS SOUTH AFRICA (Pty) Ltd**

HEAD OFFICE JOHANNESBURG • www.tvh.com

CAPE TOWN

1 Karee Street • Kraaifontein Industries • Cape Town 7571
 T +27 21 988 2432 • F +27 21 988 9127
 capetownsales@tvh.com

DURBAN

2 Monaco Place • Westmead • Pinetown 3600
 T +27 31 100 0760 • F +27 31 700 6191
 durbansales@tvh.com

JOHANNESBURG

90 Electron Avenue • Isando • Kempton Park 1601
 T +27 11 281 27 00 • F +011 974 9845
 johannesburgsales@tvh.com

LICHTENBURG

Shop 1 • 109 Scholtz Street • Lichtenburg 2740
 T +27 18 632 6192/6092 • F +27 18 632 6108
 lichtenburgsales@tvh.com

PORT ELIZABETH

134 Kempston Road • Korsten • Port Elizabeth 6020
 T +27 41 453 1404/8 • F +27 41 453 1409
 portelizabethsales@tvh.com

FOR ALL OUR LATEST CATALOGUE UPDATES AND COMPANY INFO: WWW.BEPCOPARTS.COM



The spare parts mentioned in this list can normally be delivered from stock. In addition, we can supply parts, which are not mentioned in this catalogue, with the shortest possible delivery time. The O.E.M. references are only for indication purposes and do not imply that the spare parts are coming from the manufacturer. This spare parts list can be modified without prior notice. All photographs, drawings, illustrations, brand names, descriptions and numbers are included for identification purposes only.



De onderdelen vermeld in deze lijst, zijn normaal uit voorraad leverbaar, behoudens uitverkocht. Ook niet-vermelde onderdelen kunnen binnen de kortste tijd uitgeleverd worden. De O.E.M. referenties dienen enkel ter indicatie en impliceren niet dat deze van de vermelde constructeur afkomstig zijn. Deze onderdelenlijst kan zonder enige voorafgaande verwittiging aangepast worden. Alle gebruikte foto's, tekeningen, afbeeldingen, merknamen, omschrijvingen en nummers dienen alleen ter identificatie.



Les pièces de rechange, mentionnées dans cette liste, sont normalement livrables du stock. En plus, les articles nonindiqués peuvent être fournis en peu de temps. Cette liste peut être modifiée sans avis préalable. Les références O.E.M. sont seulement indicatives et n'impliquent pas que les pièces de rechange viennent du constructeur. Toutes les photographies, illustrations, marques, descriptions, tous les plans et numéros servent exclusivement à une identification.



Die in dieser Liste aufgeführten Teile sind normalerweise ab Lager lieferbar. Wir sind zudem in der Lage, nicht aufgeführte Teile innerhalb kürzester Zeit zu liefern. Die O.E.M. Referenznummern dienen zur Information und beinhalten nicht, dass diese vom genannten Hersteller kommen. Diese Bestandsliste kann ohne vorhergehende Ankündigung geändert werden. Alle verwendeten Fotos, Zeichnungen, Abbildungen, Markennamen, Beschreibungen und Nummern dienen nur zu Identifikationszwecken.



Los artículos mencionados en este catálogo se encuentran habitualmente en stock. Además, podemos suministrar en un plazo corto de tiempo otros artículos relacionados que no se encuentren expresamente mencionados en este catálogo. Las referencias O.E.M. sirven sólo como indicación y no implican que procedan del constructor. Este listado de productos puede estar sujeto a modificaciones sin aviso previo. Todas las fotos, dibujos, ilustraciones, nombres de marca, descripciones y números se han incluido simplemente con el propósito de su identificación.



I pezzi di ricambio, menzionati in questo listino, possono essere forniti con una consegna immediata a condizione che non siano esauriti. I pezzi di ricambio non menzionati possono essere forniti in poco tempo. Le referenze O.E.M. sono solamente indicative e non implicano che i pezzi di ricambio vengano da questo costruttore. Questa lista ricambi può essere aggiustata senza avvisi anticipati. Tutti i numeri, codici, nomi, foto, spaccati e disegni sono solo a titolo informativo.



Części z tego katalogu są zazwyczaj na stanie magazynowym. Również części które nie są wyszczególnione w katalogu mogą być dostarczone na zamówienie w najkrótszym możliwym terminie. Opis części O.E.M. jest używany informacyjnie i nie wskazuje na to, że dany produkt jest wyprodukowany przez podanego producenta. Zawartość katalogu może ulec zmianie bez wcześniejszego informowania o tym. Wszystkie użyte zdjęcia, rysunki, nazwy marek, opis i numery służą tylko do identyfikacji.



Запчасти из настоящего списка, как правило, имеются в запасе, если только он не распродан. Прочие, не фигурирующие в списке артикулы, могут быть поставлены в самые кратчайшие сроки. Указание оригинальных номеров производителя не предполагает обязательного оригинального происхождения самих деталей. Данный список может изменяться без предварительного уведомления. Все использованные фото, рисунки, иллюстрации, названия брендов, наименования и номера служат исключительно для цели идентификации.

Besuchen Sie uns im Internet:
www.bepcoparts.com

© **bepco** 2015

Alle Rechte vorbehalten. Nachdruck, auch nur auszugsweise, oder die Aufnahme/Verwendung in ein Informationsspeicherung- oder Abrufsystem, nur mit schriftlicher Genehmigung der Bepco Deutschland GmbH.

- BEPCO ist ein Anbieter von After-Market-Ersatz- und Zubehörteile, für die Wartung und Reparatur von OEM-Geräten. OEM Ersatzteil-Nummern dienen ausschließlich zu Vergleichszwecken. Bei den angebotenen Ersatzteilen handelt es sich nicht, so fern nicht anders erwähnt, um original Ersatzteile.
- Fotos und Illustrationen dienen nur als Referenz. Irrtümer und Druckfehler vorbehalten.
- BEPCO® ist eine eingetragene Marke
- Alle Verkäufe unterliegen den allgemeinen Geschäftsbedingungen - verfügbar auf www.bepcoparts.com / www.bepco-deutschland.de
- Warenabgabe nur solange der Vorrat reicht

Ersatzteile ■
von A-Z für
alle Marken

■ **Perkins**

Schlepperteile
Motorenersatzteile

Klimatechnik
Verbrauchmaterial & Zubehör
Verschleißteile
Werkstattausrüstung

moving forward in every field



Bepco Deutschland GmbH

Nelmannwall 4 - 59494 Soest

T +49 (0)2921 943000

info.de@bepcoparts.com · www.bepcoparts.com · www.bepco-deutschland.de

Member of **TVH** 